

# Data Sheet

## WÖHR PARKLIFT 464 465

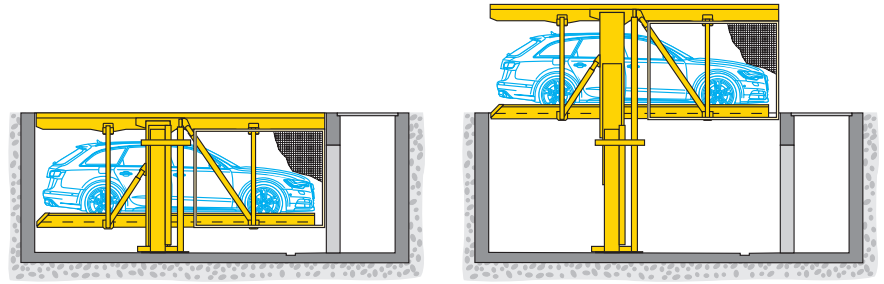

- **Single units: 1–2 cars**  
**Double units: 2–4 cars**
- **Platform load options:**
  - max. 2000 kg, load per wheel 500 kg
  - max. 2600 kg, load per wheel 650 kg
- **Platforms horizontally accessible**
- **Designed per DIN 1991-1-3 for Snow Load Zone II up to 0.75 kN/m<sup>2</sup> and a wind impact pressure of 0,25 kN/m<sup>2</sup> (corresponds to wind force 8)**



### Length dimensions (height dimensions see page 2)

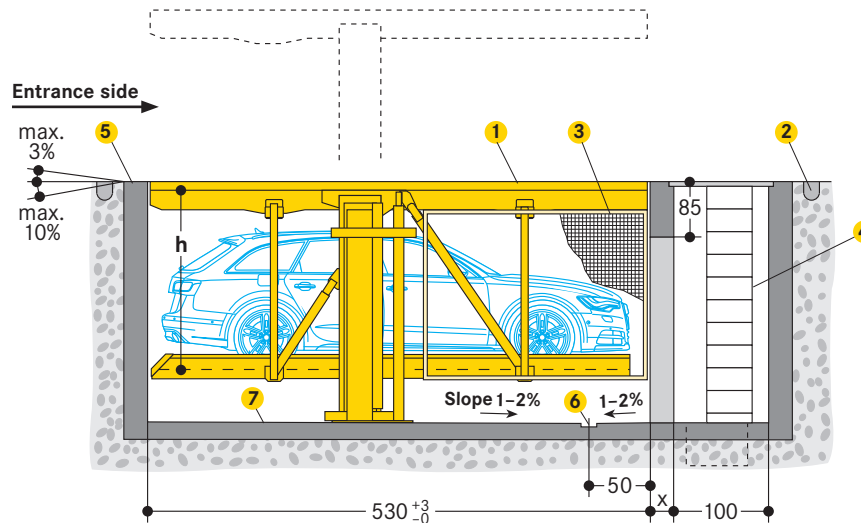

- 1 **Top platform:**
  - welded construction per EN ISO 13920, tolerance class C
  - covered with Classic Profile
  - recessed floor level traversable
  - traversable at max. vehicle weight of 2000 kg, max. wheel load 500 kg
  - usable as parking place (see page 4)
- 2 **Circumferential drainage channel to be performed by the customer (see page 7)**
- 3 **Safety mesh in the side area as required**
- 4 **Maintenance shaft:**
  - shaft ladder and access to pit have to be performed by the customer
  - shaft ladder must be installed after completion of the shell construction for dimensional inspection
  - WÖHR recommends the installation of a vertical ladder for shafts in accordance with EN 14396:2004
  - safeguard of access with a steel door to be performed by the customer
  - the opening above the maintenance shaft door must be closed by the customer with a removable grille; if you are in the maintenance shaft, it must be possible to remove the grille
- 5 **Yellow-black markings:**
  - ISO 3864, 10 cm wide, on the pit edge (see »Static calculations and construction works requirement«, page 5)
- 6 **Drainage channel in the pit:**
  - 10 x 2 cm with sump 50 x 50 x 50 cm
  - drainage with grating
  - installing a sump pump refer to manufacturer's dimensions
- 7 **Channels or undercuts/concrete haunches:**
  - not allowed along the pit floor-to-wall joints
  - should channels or undercuts be necessary, the stand areas must be left clear

### ■ Dimensions

- all dimensions specified are the minimum, finished dimensions
- tolerances must be taken into consideration
- all dimensions are given in cm

**Height dimensions PARKLIFT 464**

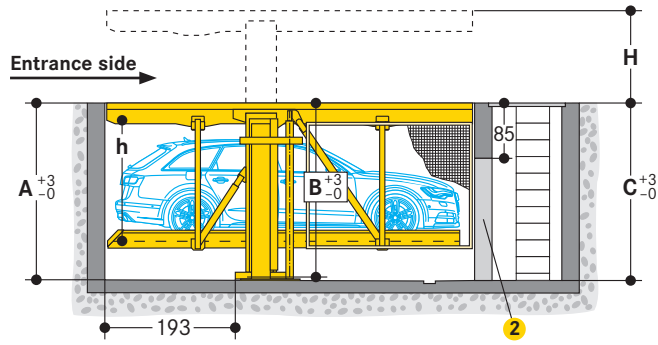

Type	Height (H)	Pit depth			Vehicle height lower level <sup>1</sup>	Platform distance (h)
		A	B	C		
464-250	200	250	254	255	L+S 165	170
464-285	235	285	289	290	L+S 200	205

- <sup>1</sup> L = Limousine / S = Station wagon
- <sup>2</sup> Wall opening

**Height dimensions PARKLIFT 465**

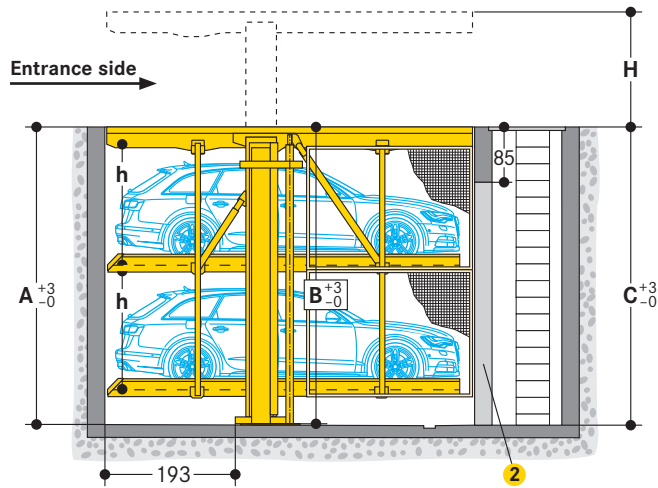

Type	Height (H)	Pit depth			Vehicle height lower level <sup>1</sup>	Platform distance (h)
		A	B	C		
465-425	380	425	429	430	L+S 165	170
465-495	450	495	499	500	L+S 200	205

- <sup>1</sup> L = Limousine / S = Station wagon
- <sup>2</sup> Wall opening

**Width dimensions**

Platform widths:

250 cm (single units), 500 cm (double units):

- for 190 cm vehicle width (without outside mirror)

260-270 cm (single units), 520-540 cm (double units):

- for vehicles wider than 190 cm (without outside mirror)

For comfortable parking, entry and exit conditions platform widths upon 250 cm are recommended. Reduced platform width means reduced parking comfort depending on the vehicle width, vehicle type, individual driving style, access situation of the garage.

**Top view closed pit**

Single unit

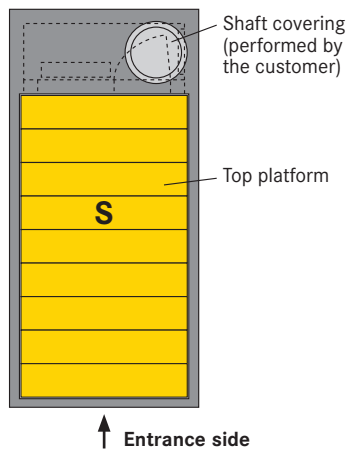

Double unit

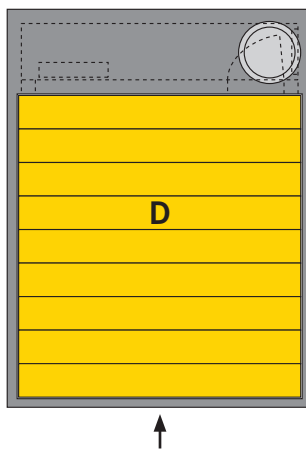

Row arrangement (single and double units combined)

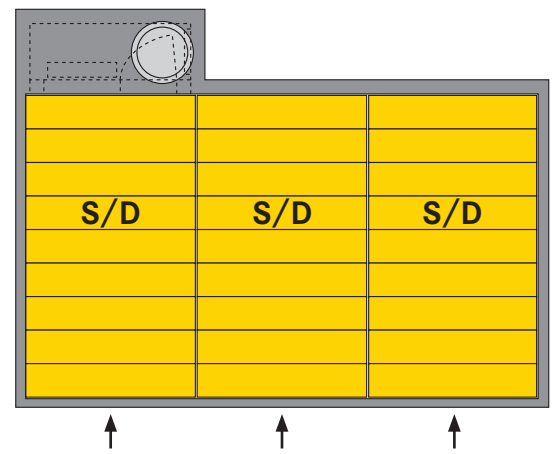

**Pit dimensions**

Single unit (front view)

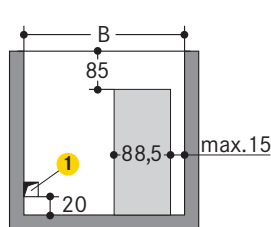

Double unit

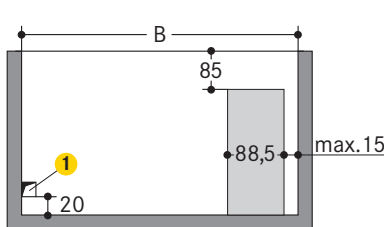

Row arrangement

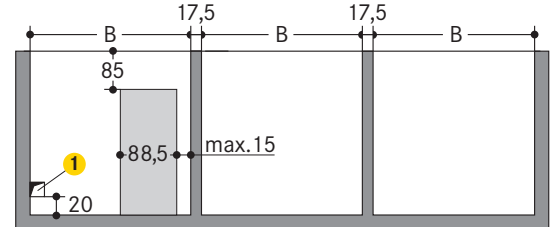

(top view)

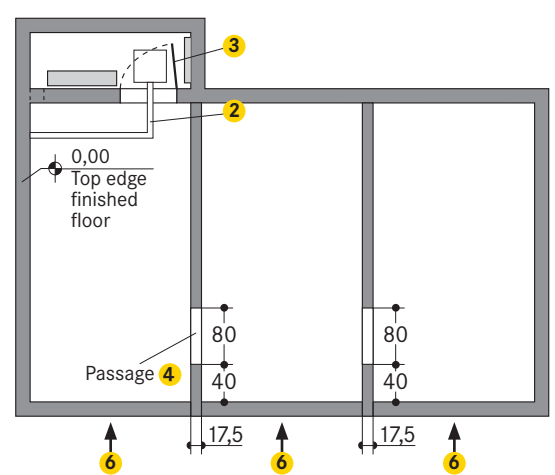
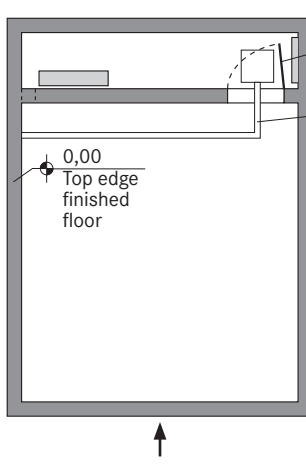
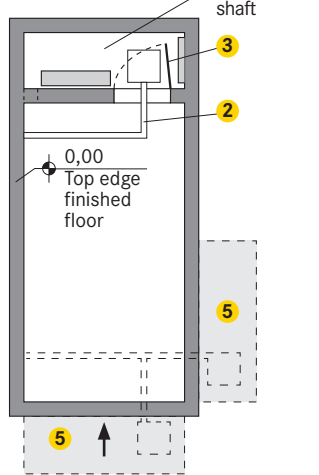

space requirements	clear platform width	
	parking level	top platform
B		
PARKLIFT 464 S		
265	230	260
275	240	270
285	250	280
295	260	290
305	270	300
PARKLIFT 465 S		
265	230	260
275	240	270
285	250	280
295	260	290
305	270	300

space requirements	clear platform width	
	parking level	top platform
B		
PARKLIFT 464 D		
495	460	490
505	470	500
515	480	510
525	490	520
535	500	530
545	510	540
555	520	550
565	530	560
575	540	570
PARKLIFT 465 D		
500	460	495
510	470	505
520	480	515
530	490	525
540	500	535
550	510	545
560	520	555
570	530	565
580	540	575

- 1 15 x 15 cm gap for hydraulic leads
- 2 Drainage channel with sump (covered with grating)
- 3 Maintenance door to be installed by the customer
- 4 Passage to neighbouring system must have the same height as the passage from the maintenance shaft to the pit. All passages to neighbouring systems must be on the entrance side.
- 5 Alternative position of the maintenance shaft (drainage channel and sump must be shifted)
- 6 In the case of a row arrangement, the entrances must all be arranged on one side

**Intermediate walls**

- side walls must be situated on the entry side in the direction of bracket (deviation max. 1 cm)

**Clearance profile (for standard vehicles)**

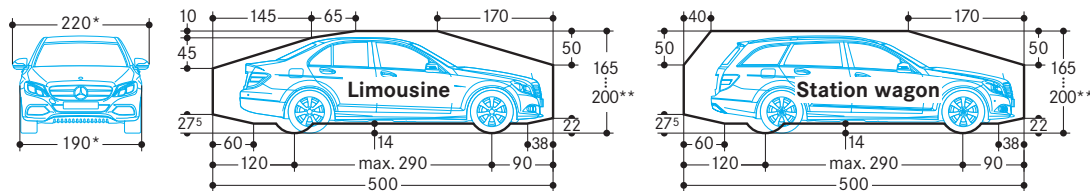

\* for a 250 cm platform width  
 \*\* the overall vehicle height including roof luggage rails and antenna mounts must not exceed the max. vehicle height dimensions specified

**Walls extending above the pit**

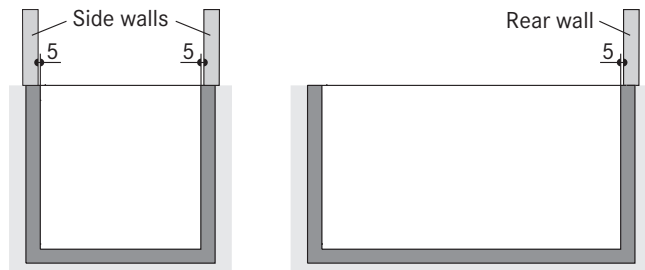

If side or rear walls above the pit edge are implemented, they must be situated 5 cm away from the pit edge.

**Pit edge**

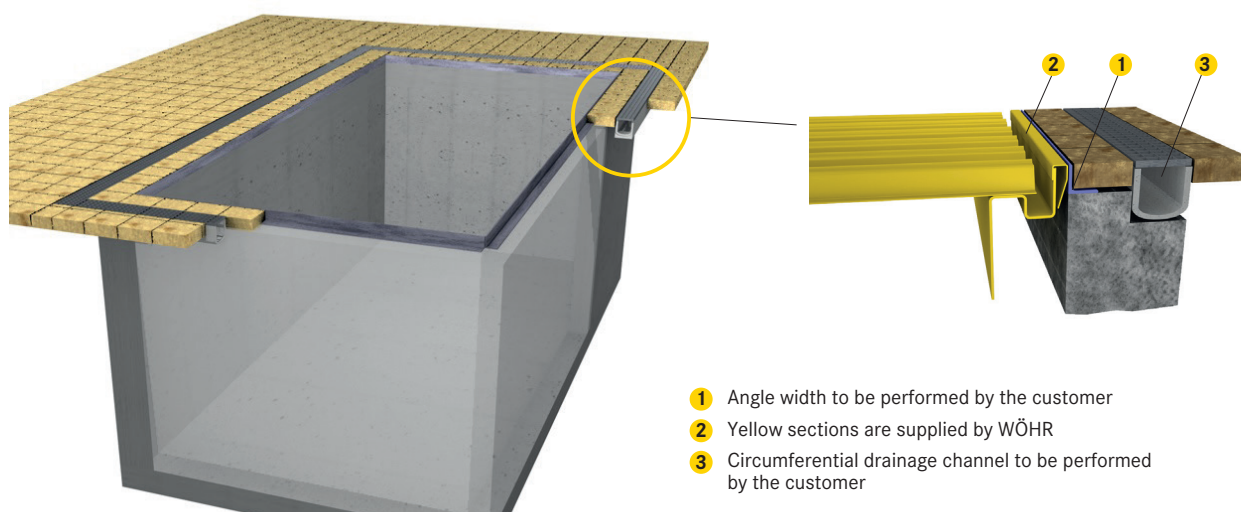

- 1 Angle width to be performed by the customer
- 2 Yellow sections are supplied by WÖHR
- 3 Circumferential drainage channel to be performed by the customer

Illustration without Parklift unit

**Parking place on the top platform**

Vehicles can be parked on the top platform if the following measure is implemented optionally.

**Wheel well made of sheet metal**

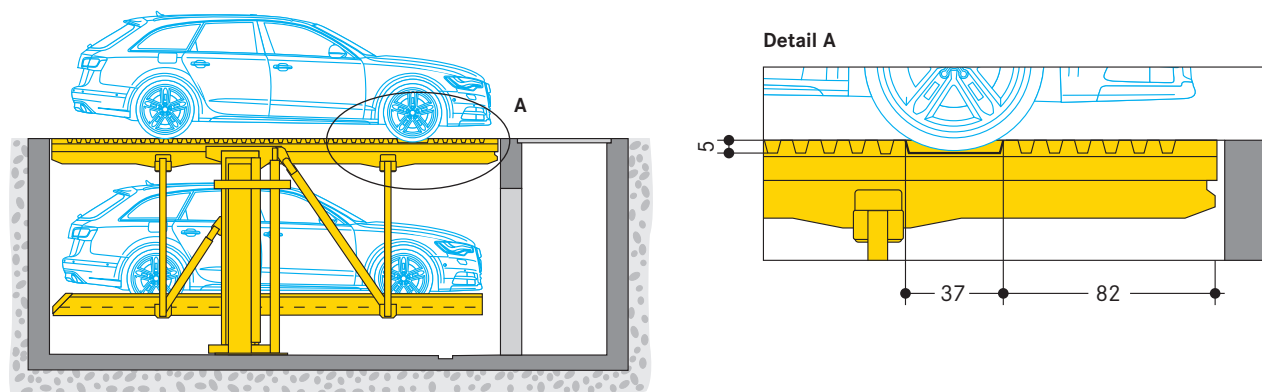

**Position of the operating device**

The entry edge of the system must be visible to the user from the position of the operating device.

The operating devices are supplied for wall mounting as standard. Foundations are required for operating devices with stands for attachment to the floor (at extra cost).

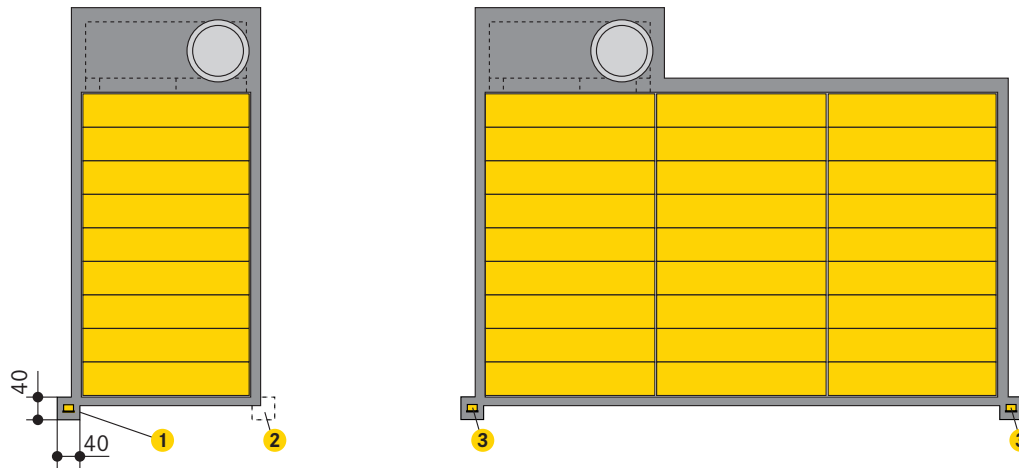

- 1 Foundation for operating device. Wiring see page 7.
- 2 Alternative position of the foundation.
- 3 Optional: Several operating devices are mutually electrically interlocked. Only one system can be moved at a time.

**Static calculations and construction works requirement**

**Top view**

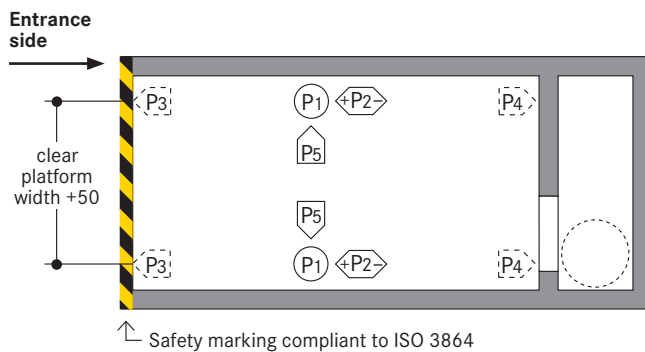

**Section**

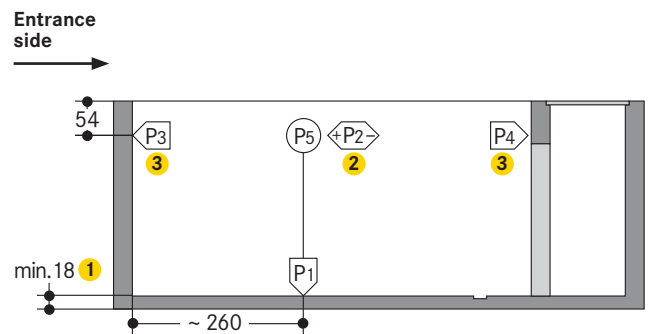

Fixing of the system frames to the floor slab:  
 - using base plates  
 - using adhesive anchor bolts  
 - hole depth to 12-14 cm  
 - concrete thickness of at least 18 cm

Concrete quality grade:  
 - compliant to the static requirements of the construction  
 - min. C20/25 grade (for dowel fastening)

Walls:  
 - out of concrete  
 - completely even  
 - without protruding pieces such as edge mounts, pipes, etc  
 - planarity and angularity tolerances per DIN 18202 to be observed

Frame bearing points:  
 - the specified lengths are expressed as mean value

- 1 Floor slab capacity is verified through a structural engineer, under the circumstances where a thicker floor slab is needed
- 2 The P2 load only applies if the pillars are fastened on the side walls
- 3 The P3 and P4 loads only apply if the pillars cannot be fastened to the side walls

**Static data PARKLIFT 464**

**PARKLIFT 464 – 2000 kg**

Single unit	Double unit
P1 = + 60 kN*	P1 = + 115 kN
P2 = ± 9 kN	P2 = ± 15 kN
P3 = + 9 kN	P3 = + 15 kN
P4 = + 9 kN	P4 = + 15 kN
P5 = + 9 kN	P5 = + 11 kN

**PARKLIFT 464 – 2600 kg**

Single unit	Double unit
P1 = + 65 kN*	P1 = + 130 kN
P2 = ± 10 kN	P2 = ± 16 kN
P3 = + 10 kN	P3 = + 16 kN
P4 = + 10 kN	P4 = + 16 kN
P5 = + 10 kN	P5 = + 13 kN

\* specified load bearing data includes the vehicle weight

**Static data PARKLIFT 465**

**PARKLIFT 465 – 2000 kg**

Single unit	Double unit
P1 = + 80 kN*	P1 = + 160 kN
P2 = ± 11 kN	P2 = ± 16 kN
P3 = + 11 kN	P3 = + 16 kN
P4 = + 11 kN	P4 = + 16 kN
P5 = + 9 kN	P5 = + 13 kN

**PARKLIFT 465 – 2600 kg**

Single unit	Double unit
P1 = + 90 kN*	P1 = + 180 kN
P2 = ± 11 kN	P2 = ± 18 kN
P3 = + 11 kN	P3 = + 18 kN
P4 = + 11 kN	P4 = + 18 kN
P5 = + 11 kN	P5 = + 14 kN

\* specified load bearing data includes the vehicle weight

**Electrical specifications**

**Installation diagram**

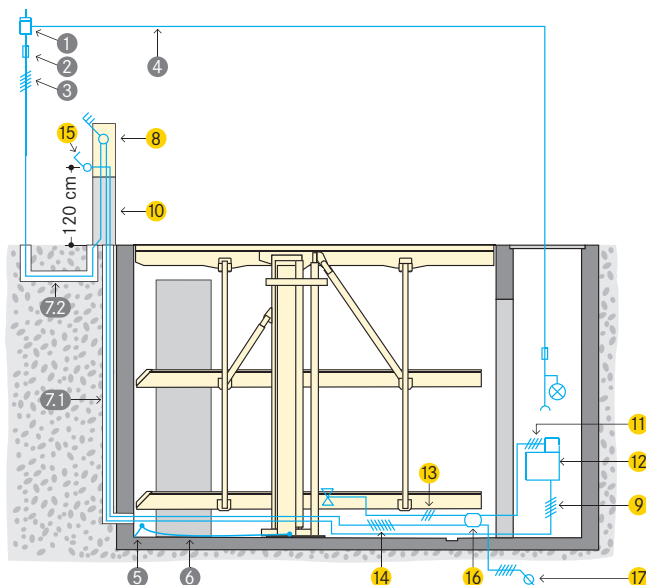

**Cabling preparation to be performed by the customer:**

- up to the main switch to be in place prior to starting the installation operations
- connection to the main switch during installation
- system functional check testing can be performed by WÖHR together with the electrician provided by the customer
- if requested at a later date, functional check testing can be performed by WÖHR at extra-cost

**Grounding and potential equalisation:**

- to be performed by the customer compliant to DIN EN 60204
- connections required every 10 metres

**To be performed by the customer**

Item	Quantity	Description	Position	Recurrence
1	1 piece	power meter	in the feed cable	
2	1 piece	fuse protection or automatic circuit breaker compliant to DIN VDE 0100 part 430: - 3 x 25 A slow blow for 5,5 kW power pack (starting current 57 A)	in the feed cable	1 x per power pack
3	based on site conditions	compliant to local power supply regulations* 3 phases + N + PE* 230/400 V, 50 Hz	feed cables to main switch	1 x per power pack
4	1 piece	separate power supply of 230 V with safeguard, lighting, and power point	from the electric meter in the maintenance shaft	1 x per system
5	every 10 m	grounding and potential equalisation lead-out connection	along pit floor edges/rear wall	
6	1 piece	grounding and potential equalisation compliant to DIN EN 60204	from lead-out connection to system	1 x per system
7.1	based on site conditions	empty pipe DN 40 with taut wire	base pit/operating device	1 x per system
7.2	based on site conditions	empty pipe DN 40 with taut wire	supply to the main switch	1 x per system

\* to DIN VDE 0100 sections 410 and 430 (no permanent load) 3 phases + N+ PE (three phase current)

**Scope of delivery by WÖHR (unless otherwise specified)**

Item	Description
8	Lockable main switch
9	5 x 4,0 mm <sup>2</sup> control cable leading from the main switch to the power pack
10	Adjustable stand (at extra cost)
11	4 x 1,5 mm <sup>2</sup> control cable
12	Hydraulic power pack with three-phase motor 5,5 kW. Ready-wired switching cabinet with motor safety contactor
13	3 x 1,5 mm <sup>2</sup> control cable for the cylinder valve lead (below the lowest platform)
14	7 x 1,5 mm <sup>2</sup> control cable (below the lowest platform)
15	UP/down operating unit with EMERGENCY STOP. Key can be removed only when in the lower end position (key blocking). Cable feed-in strictly from below leading upwards (2 keys for each parking space). The entry edge of the system must be visible to the user from the position of the operating device.
16	Branch connector (below the lowest platform)
17	5 x 1,5 mm <sup>2</sup> control cable lead-out to the system alongside (below the lowest platform)

## Notes and directions

### Scope of application

- suitable for residential buildings
- retrofitting to accommodation
- only for long-term users that have been instructed on how to use the system

### Noise reduction measures (outdoor installation)

Basis:

- to the German DIN 4109 »Noise protection in buildings«
- at devices, machines, and facilities, household appliances must provide adequate protection against transmission over air and structure-borne sound

Structure-borne sound transmission:

- since the facilities are mainly built free-standing, measures against structure-borne noise are not expected

### Drainage

Discharge of larger volumes of water from the property:

- circumferential drainage channel outside the pit have to be performed by the customer (see page 4, chapter pit edge, item 3)

Water entry into the pit:

- in winter through snow in the wheelhouse up to 40 litres for every parking action

Drainage channel in pit area:

- connection to the floor intake or sump to be performed by the customer (50 x 50 x 50 cm)
- sump covered with grating to be performed by the customer
- customer-performed installation of a pump or drain

Sideways slope drainage:

- only into a drainage channel
- not possible in the remaining pit section

Lengthways slope drainage:

- provided according to specified construction dimensions

Environmental safety:

- coating of the pit flooring is recommended
- installation of an oil and/or petrol separator unit between the drainage connection and the main sewerage system is recommended

### Ventilation

A ventilation system designed by a specialist company is required for trouble-free operation of the system.

Goal of the measures:

- continuous air exchange
- reduction of humidity
- preventing condensation due to introduced vehicle temperature
- removal of moisture from vehicles (through rain, snow, ice, etc.)

These measures carry substantial reductions of corrosion and resulting disturbances.

### Temperature

- system operating range: -20° to +40°C (with unloaded platforms lowering speed is reduced if less than +5° C)
- humidity: 50% at +40°C
- in the event of changes to system conditions please consult with WÖHR

### Operating device

- position of the operating device will be defined depending on the project (adjustable stand or house wall)
- empty pipe DN40 with taut wire from the floor of the shaft to the operating device have to be performed by the customer
- system must be run from the controls always in the lowermost end position (key blocking)

### Lighting

- sufficient lighting of the driving aisle and of the parking places must be performed by the customer
- brightness of lighting in the maintenance shaft and in the pit at least 80 lux

### Fire safety

- all fire safety requirements and all mandatory equipment (fire extinguisher and fire alarm systems, etc.) must be performed by the customer

### Conformity examination (TÜV)



- voluntary conformity assessment by the TÜV SÜD
- The parking systems are compliant to:
  - EC Machinery Directive 2006/42/EC
  - DIN EN 14010

### Protection

- protection of the pit during construction phase has to be performed by the customer

### Hydraulic power pack

- the hydraulic power pack will be housed in the maintenance shaft

### Maintenance shaft

- separate maintenance shaft with access to pit has to be performed by the customer
- project-dependent common maintenance shaft at row arrangement possible
- manhole cover and shaft ladder have to be performed by the customer
- WÖHR recommends the installation of a vertical ladder for shafts in accordance with EN 14396:2004
- the manhole cover must prevent rainwater and surface water from entering the maintenance shaft

### Mounting

- crane for mounting to be performed by customer
- for mounting in underground garage or rooftop areas, mobile crane (radius minimum 5 metres) to be performed by customer

#### PARKLIFT 464:

- minimum hook height of 400 cm over entry level, crane load approx. 700 kg

#### PARKLIFT 465:

- minimum hook height of 700 cm over entry level, crane load approx. 1400 kg

### Important note

Warning:

- in case the side or rear area freely accessible, safeguards are required (sites, markings, electric line switch, among others)
- safeguards will be planned project by project

### Maintenance

- WÖHR and all the WÖHR partners abroad provide an installation and customer service network
- regular, annual maintenance is provided subject to the stipulation of a maintenance agreement

### Prevention of corrosion damage

- all operations listed in the WÖHR Cleaning and Maintenance Instructions are to be performed regularly (independently of maintenance operations)
- zinc-plated parts, components and platforms are to be kept clean of dirt, road-salt and any other debris (due to corrosion hazards)
- always keep the garage well ventilated and deaerated



### Surface protection

- please consider the information on surface protection!



### Parking Place-Profile

- please consider the product information Parking Place-Profile!



### Electromobility

- please consider the product information E-charging!
- depending on the position of the charging point on the electric vehicle, collision points with protruding plugs and charging cables can occur



### Construction formalities

- the documentation necessary for construction permit applications is provided by WÖHR on demand

### Construction alterations and/or modifications

- the right to construction or model modifications and/or variations is hereby reserved
- the right to any subsequent part modification and/or variation and amendments in procedures and standards due to technical and engineering progresses or due to environmental regulation changes is also hereby reserved